



Data Book

AU9362

USB Multiple Slots Flash Memory Card Reader

Technical Reference Manual

Product Specification

Official Release

Revision 1.00W

Public

Jan 2005



Data sheet status

| | |
|---------------------------|---|
| Objective specification | This data sheet contains target or goal specifications for product development. |
| Preliminary specification | This data sheet contains preliminary data; supplementary data may be published later. |
| Product specification | This data sheet contains final product specifications. |

Revision History

| Date | Revision | Description |
|----------|-----------|---|
| Jan 2005 | 1.00W/A21 | Removed the schematics. Please contact our sales if you need it. |
| | | |
| | | |
| | | |



Copyright Notice

Copyright 1997 - 2005
Alcor Micro Corp.
All Rights Reserved.

Trademark Acknowledgements

The company and product names mentioned in this document may be the trademarks or registered trademarks of their manufacturers.

Disclaimer

Alcor Micro Corp. reserves the right to change this product without prior notice. Alcor Micro Corp. makes no warranty for the use of its products and bears no responsibility for any error that appear in this document. Specifications are subject to change without prior notice

Contact Information:

Web site: <http://www.alcormicro.com/>

Taiwan

Alcor Micro Corp.
4F, No 200 Kang Chien Rd., Nei Hu,
Taipei, Taiwan, R.O.C.
Phone: 886-2-8751-1984
Fax: 886-2-2659-7723

Santa Clara Office

2901 Tasman Drive, Suite 206
Santa Clara, CA 95054
USA
Phone: (408) 845-9300
Fax: (408) 845-9086

Los Angeles Office

9070 Rancho Park Court
Rancho Cucamonga, CA.91730
USA
Phone: (909) 483-9900
Fax: (909) 944-0464



Table of Contents

| | | |
|----------|--|-----------|
| 1 | <u>Introduction</u> | 6 |
| 1.1 | <u>Description</u> | 6 |
| 1.2 | <u>Features</u> | 6 |
| 2 | <u>Application Block Diagram</u> | 7 |
| 3 | <u>Operation Mode Selection</u> | 8 |
| 4 | <u>Pin Assignment</u> | 9 |
| 5 | <u>System Architecture and Reference Design</u> | 12 |
| 5.1 | <u>AU9362 Block Diagram</u> | 12 |
| 6 | <u>Electrical Characteristics</u> | 13 |
| 6.1 | <u>Absolute Maximum Ratings</u> | 13 |
| 6.2 | <u>Recommended Operating Conditions</u> | 13 |
| 6.3 | <u>General DC Characteristics</u> | 13 |
| 6.4 | <u>DC Electrical Characteristics for 5 volts operation</u> | 14 |
| 6.5 | <u>Crystal Oscillator Circuit Setup for Characterization</u> | 16 |
| 6.6 | <u>USB Transceiver Characteristics</u> | 15 |
| 6.7 | <u>ESD Test Results</u> | 19 |
| 6.8 | <u>Latch-Up Test Results</u> | 20 |
| 7 | <u>Mechanical Information</u> | 22 |
| 8 | <u>Abbreviations</u> | 23 |



List of Figures

| | | |
|-----|---|----|
| 2.1 | Block Diagram | 7 |
| 4.1 | Pin Assignment Diagram | 9 |
| 5.1 | AU9362 Block Diagram | 12 |
| 6.1 | Crystal Oscillator Circuit Setup for Characterization Diagram | 14 |
| 6.2 | Electrical Characteristics Diagram | 18 |
| 6.3 | Latch-Up Test Results Diagram | 20 |
| 7.1 | Mechanical Information Diagram | 22 |

List of Tables

| | | |
|------|---|----|
| 3.1 | Mode Table | 8 |
| 4.1 | Pin Descriptions | 10 |
| 6.1 | Absolute Maximum Ratings | 13 |
| 6.2 | Recommended Operating Conditions | 13 |
| 6.3 | General DC Characteristics | 13 |
| 6.4 | DC Electrical Characteristics for 5 Volts operation | 14 |
| 6.5 | Recommended Operation Conditions | 15 |
| 6.6 | Absolute Maximum Ratings | 15 |
| 6.7 | DC Electrical Characteristics | 16 |
| 6.8 | AC Electrical Characteristics | 17 |
| 6.9 | ESD Data | 19 |
| 6.10 | Latch-Up Data Table | 21 |
| 7.1 | Mechanical Information Table | 22 |



1.0 Introduction

1.1 Description

The AU9362 is a single chip USB flash memory reader controller which supports the widely used flash memory cards such as Compact Flash (CF) card, Micro Drive (MD), Smart Media Card (SMC), XD Picture Card, Memory Stick (MS), Memory Stick Duo, Memory Stick PRO, Secure Digital (SD) and Multimedia Card (MMC). It can be used as removable storage disks in enormous data exchange applications between PC and PC or PC and various consumer electronic appliances.

The AU9362 reads digital contents saved on memory card that user captured with consumer electronic devices such as digital cameras, MP3 players, PDAs and mobile phones... etc.

In addition, AU9362 allows user to transfer information such as data, graphics, texts or digital images from one electronic device to another quickly and easily. With AU9362, users' experience will be further enhanced by the Plug-and-Play nature built into latest operation systems such as Windows 2000/XP and Mac OS X.

1.2 Features

- Support USB v1.1 specification and USB Device Class Definition for Mass Storage, Bulk-Transport v1.0
- Support Compact Flash (CF) v1.4 Specification
- Support Secure Digital (SD) v1.0 Specification.
- Support Memory Stick (MS) v1.3 Specification.
- Support Memory Stick PRO v1.0 Specification.
- Support Memory Stick ROM Format v1.0 Specification.
- Support Smart Media Card (SMC) Standard 2000 Specification.
- Support xD-Picture Card Format V1.0 Specification
- Support IBM Microdrive device.
- Work with default driver from Windows ME, Windows XP, Mac OS 9, and Mac OS X. Windows 98, Windows 2000 are supported by vendor driver from Alcor.
- Ping-pong FIFO implementation for concurrent bus operation
- Support multiple sectors transfer to 4GB to optimize performance
- Support optional external EEPROM for USB VID, PID and string customization
- Support multiple slot concurrent operation.
- Integrated power switch and power management circuit for each slot to meet USB 500uA power consumption during suspend with card in the slot.
- Runs at 12MHz, built-in 48 MHz PLL
- Built-in 3.3V regulator
- 64-pin LQFP package

2.0 Application Block Diagram

Following is the application diagram of a typical flash memory card reader using AU9362. By connecting the reader to a PC through USB bus, the AU9362 is acting as a bridge between the flash memory card from digital camera, MP3 player, PDA or mobile phone and PC.

Figure 2.1 Block Diagram

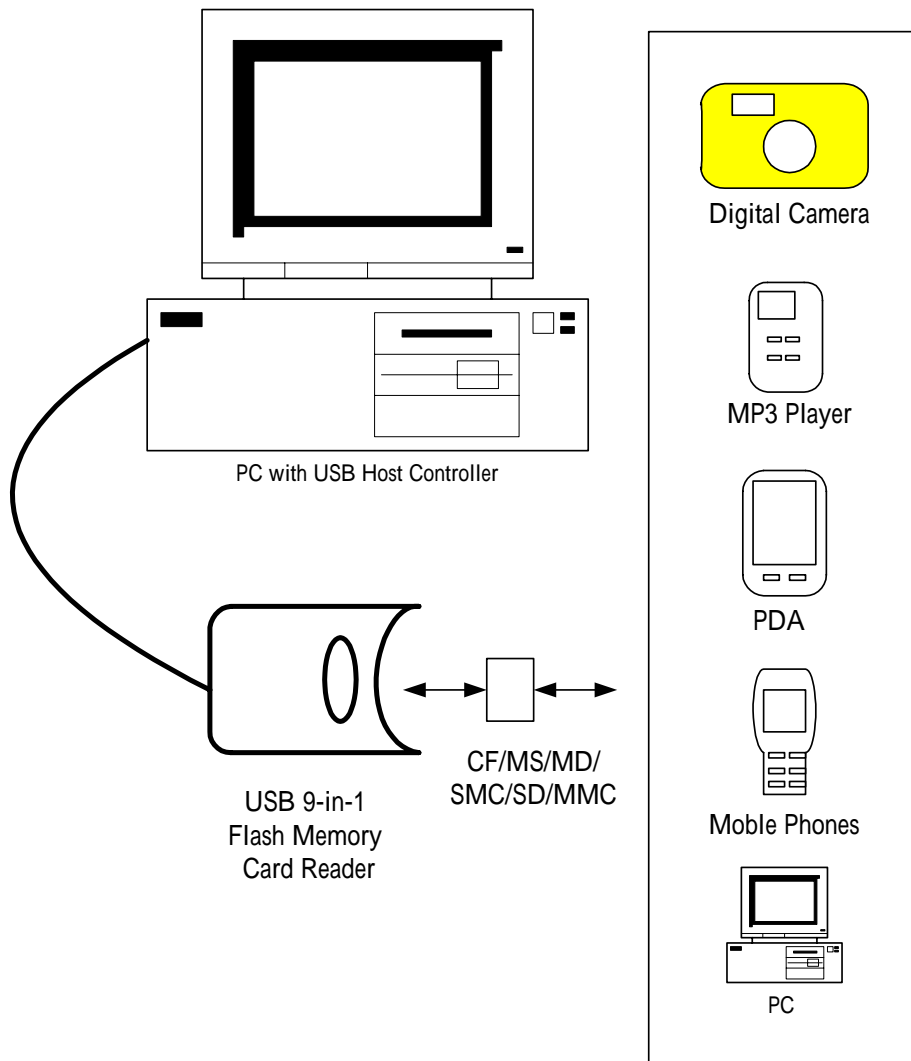



3.0 Operating Mode Selection

The Au9362 offers two operating modes. Mode 0 is used for SD/SMC/MS combo socket. While mode 1 is designed for single function socket. Mode 1 support xD card in a shared SMC socket.

Table 3.1 Mode Table

| Mode 0 (2SLOTSEL : 0) | | Mode 1 (2SLOTSEL : 1) | |
|-----------------------|-----------|-----------------------|--------|
| Slot 1 | CF | Slot 1 | SD |
| | | Slot 2 | CF |
| Slot 2 | SD/SMC/MS | Slot 3 | SMC/XD |
| | | Slot 4 | MS |



4.0 Pin Assignment

The AU9362 is packed in 64-LQFP-form factor. The following figure shows signal name for each pin and the table in the following page describes each pin in detail.

Figure 4.1 Pin Assignment Diagram

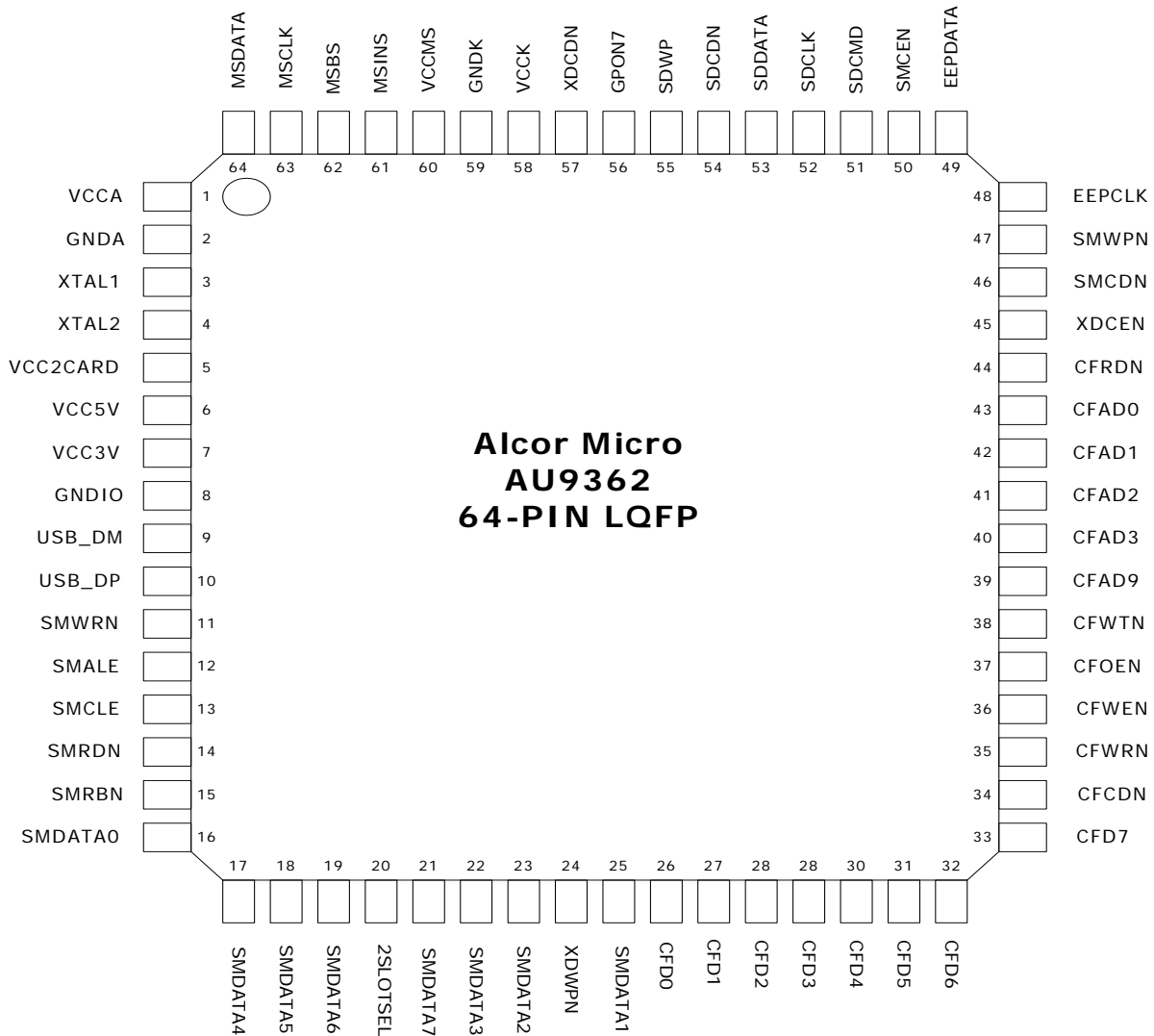



Table 4-1. Pin Descriptions

| Pin | Pin Name | I/O Type | Description |
|-----|----------|----------|---|
| 1 | VCCA | PWR | Analog 3.3V input. |
| 2 | GND A | PWR | Ground. Analog ground. |
| 3 | XTAL1 | I | Crystal Oscillator Input (12MHz). |
| 4 | XTAL2 | O | Crystal Oscillator Output (12MHz). |
| 5 | VCC2CARD | O | Connect to Card Power. |
| 6 | VCC5V | PWR | 5V power supply from USB connector. |
| 7 | VCC3V | PWR | Internally regulated 3.3V power supply output. |
| 8 | GNDIO | PWR | Ground : I/O |
| 9 | USB_DM | I/O | USB DM. |
| 10 | USB_DP | I/O | USB DP. |
| 11 | SMWRN | O | SMC Write Enable. (0: write enable, 1: write disable.) |
| 12 | SMALE | O | SMC Address Latch Enable. (0: ALE closed, 1: ALE open.) |
| 13 | SMCLE | O | SMC Command Latch Enable. (0: CLE closed, 1: CLE open.) |
| 14 | SMRDN | O | SMC Read Enable. (0: read enable, 1: read disable.) |
| 15 | SMRBN | I | SMC Ready/Busy. (0: busy, 1: ready.) |
| 16 | SMDATA0 | I/O | SMC Data0. |
| 17 | SMDATA4 | I/O | SMC Data4. |
| 18 | SMDATA5 | I/O | SMC Data5. |
| 19 | SMDATA6 | I/O | SMC Data6. |
| 20 | 2SLOTSEL | I | Mode Selection. (0: 2 slots mode, 1: 4 slots mode.) |
| 21 | SMDATA7 | I/O | SMC Data7. |
| 22 | SMDATA3 | I/O | SMC Data3. |
| 23 | SMDATA2 | I/O | SMC Data2. |
| 24 | XDWPN | I | XD Write protect (0: protect, 1: not protect.) |
| 25 | SMDATA1 | I/O | SMC Data1. |
| 26 | CFD0 | I/O | CF Card Data0. |
| 27 | CFD1 | I/O | CF Card Data1. |
| 28 | CFD2 | I/O | CF Card Data2. |
| 29 | CFD3 | I/O | CF Card Data3. |
| 30 | CFD4 | I/O | CF Card Data4. |
| 31 | CFD5 | I/O | CF Card Data5. |
| 32 | CFD6 | I/O | CF Card Data6. |
| 33 | CFD7 | I/O | CF Card Data7. |
| 34 | CFCDN | I | CF Card Detect. Internal pull-up pad. |
| 35 | CFWRN | O | CF Card IOWRN. |
| 36 | CFWEN | O | CF Card WE. |
| 37 | CFOEN | O | CF Card OE. |
| 38 | CFWTN | I | CF Card WAIT. |
| 39 | CFAD9 | O | CF Card Addr9. |
| 40 | CFAD3 | O | CF Card Addr3. |
| 41 | CFAD2 | O | CF Card Addr2. |
| 42 | CFAD1 | O | CF Card Addr1. |
| 43 | CFAD0 | O | CF Card Addr0. |
| 44 | CFRDN | O | CF Card IORD. |
| 45 | XDCEN | O | XD Card Enable. (0: enable, 1: disable.) |
| 46 | SMCDN | I | SMC Card Detect. Internal pull-up pad. |
| 47 | SMWPN | I | SMC Write Protect. (0: protected, 1: not protected.) |
| 48 | EEPCLK | O | EEPROM Serial Clock. |
| 49 | EEPDATA | I/O | EEPROM Serial Data. |
| 50 | SMCEN | O | SMC Enable. (0: disable, 1: enable.) |



| | | | |
|----|--------|-----|--|
| 51 | SDCMD | I/O | SD CMD. |
| 52 | SDCLK | O | SD CLK. |
| 53 | SDDATA | I/O | SD Data. |
| 54 | SDCDN | I | SD Card Detect. Internal pull-up pad. |
| 55 | SDWP | I | SD Write Protect. |
| 56 | GPON7 | I/O | General Purpose Out, used as activity LED. |
| 57 | XDCDN | I | XD Card Detect. Internal pull-up pad. |
| 58 | VCCK | PWR | Core 3.3V Input. |
| 59 | GNDK | PWR | Ground. |
| 60 | VCCMS | PWR | MS 3.3V Input. |
| 61 | MSINS | I | MS Card INS. Internal pull-up pad. |
| 62 | MSBS | O | MS Card BS. |
| 63 | MSCLK | O | MS Card SCLK. |
| 64 | MSDATA | I/O | MS Card DATA. |

5.0 System Architecture and Reference Design

5.1 AU9362 Block Diagram

Figure 5.1 AU9362 Block Diagram

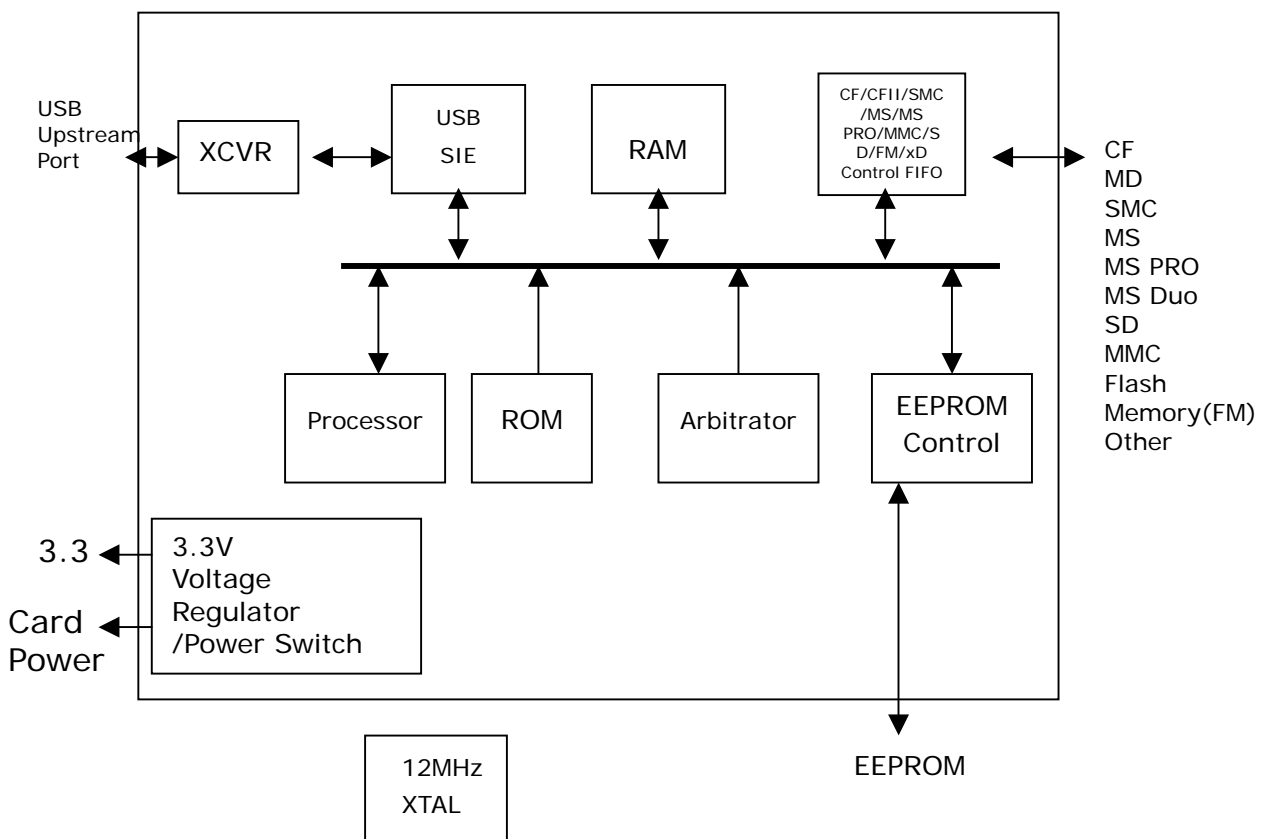



6.0 Electrical Characteristics

6.1 Absolute Maximum Ratings

Table 6.1 Absolute Maximum Ratings

| SYMBOL | PARAMETER | RATING | UNITS |
|------------------|---------------------|------------------------------|-------|
| V _{CC} | Power Supply | -0.3 to 6.0 | V |
| V _{IN} | Input Voltage | -0.3 to V _{CC} +0.3 | V |
| V _{OUT} | Output Voltage | -0.3 to V _{CC} +0.3 | V |
| T _{STG} | Storage Temperature | -40 to 125 | °C |

6.2 Recommended Operating Conditions

Table 6.2 Recommended Operating Conditions

| SYMBOL | PARAMETER | MIN | TYP | MAX | UNITS |
|------------------|-----------------------|-----|-----|-----------------|-------|
| V _{CC} | Power Supply | 4.5 | 5.0 | 5.5 | V |
| V _{IN} | Input Voltage | 0 | | V _{CC} | V |
| T _{OPR} | Operating Temperature | -5 | | 85 | °C |

6.3 General DC Characteristics

Table 6.3 General DC Characteristics

| SYMBOL | PARAMETER | CONDITIONS | MIN | TYP | MAX | UNITS |
|------------------|-----------------------------------|-------------------------|-----|-----|-----|-------|
| I _{IL} | Input low current | no pull-up or pull-down | -1 | | 1 | μA |
| I _{IH} | Input high current | no pull-up or pull-down | -1 | | 1 | μA |
| I _{OZ} | Tri-state leakage current | | -10 | | 10 | μA |
| C _{IN} | Input capacitance | | | 4 | | pF |
| C _{OUT} | Output capacitance | | | 4 | | pF |
| C _{BID} | Bi-directional buffer capacitance | | | 4 | | pF |

6.4 DC Electrical Characteristics for 5 volts operation

Table 6.4 DC Electrical Characteristics for 5 volts operation

(Under Recommended Operating Conditions and $V_{CC}=4.5v \sim 5.5v$, $T_j = -40^{\circ}C$ to $+ 85^{\circ}C$)

| SYMBOL | PARAMETER | CONDITIONS | MIN | TYP | MAX | UNITS |
|----------|-------------------------------|---------------------------------|----------------|------|----------------|------------|
| V_{IL} | Input Low Voltage | TTL | | | 0.8 | V |
| V_{IL} | Input Low Voltage | CMOS | | | $0.3 * V_{CC}$ | V |
| V_{IL} | Schmitt input Low Voltage | TTL | | 1.10 | | V |
| V_{IL} | Schmitt input Low Voltage | CMOS | | 1.84 | | V |
| V_{IH} | Input High Voltage | TTL | 2.2 | | | V |
| V_{IH} | Input High Voltage | CMOS | $0.7 * V_{CC}$ | | | V |
| V_{IH} | Schmitt input High Voltage | TTL | | 1.87 | | V |
| V_{IH} | Schmitt input High Voltage | CMOS | | 3.22 | | V |
| V_{OL} | Output low voltage | $I_{OL}=2, 4, 8, 12, 16, 24$ mA | | | 0.4 | V |
| V_{OH} | Output high voltage | $I_{OH}=2, 4, 8, 12, 16, 24$ mA | 3.5 | | | V |
| R_i | Input Pull-up/down resistance | $V_{il}=0_v$ or $V_{ih}=V_{CC}$ | | 50 | | K Ω |

6.5 Crystal Oscillator Circuit Setup for Characterization

The following setup was used to measure the open loop voltage gain for crystal oscillator circuits. The feedback resistor serves to bias the circuit at its quiescent operating point and the AC coupling capacitor, C_s , is much larger than C_1 and C_2 .

Figure 6.1 Crystal Oscillator Circuit Setup for Characterization

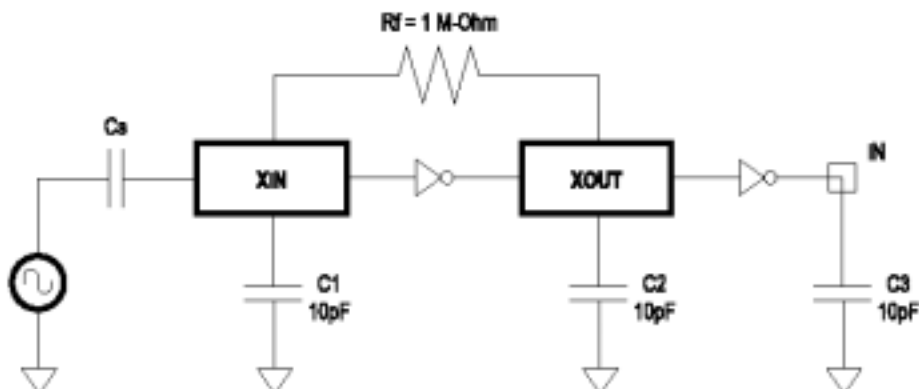



6.6 USB Transceiver Characteristics

RECOMMENDED OPERATING CONDITIONS

Table 6.5 Recommended Operating Conditions

| SYMBOL | PARAMETER | CONDITIONS | LIMITS | | UNIT |
|-----------|---|---|--------|----------|--------------|
| | | | MIN | MAX | |
| V_{CC} | DC supply voltage | | 3.0 | 3.6 | V |
| V_I | DC input voltage range | | 0 | 5.5 | V |
| $V_{I/O}$ | DC input range for I/Os | | 0 | V_{CC} | V |
| V_O | DC output voltage range | | 0 | V_{CC} | V |
| T_{AMB} | Operating ambient temperature range in free air | See DC and AC characteristics for individual device | 0 | 70 | $^{\circ}$ C |

ABSOLUTE MAXIMUM RATINGS (Notes 1 and 2)

Table 6.6 Absolute Maximum Rating System

In accordance with the Absolute Maximum Rating System, Voltages are referenced to GND (Ground=0v)

| SYMBOL | PARAMETER | CONDITIONS | LIMITS | | UNIT |
|-------------------|--|-----------------------------|--------|----------------|--------------|
| | | | MIN | MAX | |
| V_{CC} | DC supply voltage | | -0.5 | +6.5 | V |
| I_{IK} | DC input diode current | $V_i < 0$ | | -50 | mA |
| V_I | DC input voltage | Note 3 | -0.5 | +5.5 | V |
| $V_{I/O}$ | DC input voltage range for I/Os | | -0.5 | $V_{CC} + 0.5$ | V |
| I_{OK} | DC output diode current | $V_o > V_{CC}$ or $V_o < 0$ | | +/-50 | mA |
| V_O | DC output voltage | Note 3 | -0.5 | $V_{CC} + 0.5$ | V |
| I_o | DC output source sink current for VP/VM and RCV pins | $V_o = 0$ to V_{CC} | | +/-15 | mA |
| I_o | DC output source or sink current for D+/D- pins | $V_o = 0$ to V_{CC} | | +/-50 | mA |
| I_{CC}, I_{GND} | DC V_{CC} or GND current | | | +/-100 | mA |
| T_{STO} | Storage temperature range | | -60 | +150 | $^{\circ}$ C |
| P_{TOT} | Power dissipation per package | | | | mW |

NOTES:

1. Stresses beyond those listed may cause permanent damage to the device. These are stress ratings only and functional operation of the device at these or any other conditions beyond those indicated under "Recommended Operating Conditions" is not implied. Exposure to absolute maximum rated conditions for extended periods may affect device reliability.
2. The performance capability of a high performance integrated circuit in conjunction with its thermal environment can create junction temperatures which are detrimental to reliability. The maximum junction temperature of this integrated circuit should not exceed 150 $^{\circ}$ C.
3. The input and output voltage ratings may be exceeded if the input and output clamp



current ratings are observed.

DC ELECTRICAL CHARACTERISTICS

Over recommended operating conditions. Voltages are referenced to GND (Ground=0V).

Table 6.7 DC ELECTRICAL CHARACTERISTICS

| SYMBOL | PARAMETER | TEST CONDITIONS | LIMITS -40 °C to +85 °C | | | UNIT |
|-------------------|------------------------------------|---|----------------------------|--------|-------------------|------|
| | | | MIN | TYP | MAX | |
| VHYS | Hysteresis on inputs | Vcc=3.0V to 3.6V (Note 3) | 0.3 | 0.4 | 0.5 | V |
| VIH | HIGH level input | Vcc=3.0V to 3.6V (Note 3) | | 1.5 | 2.0 | V |
| VIL | LOW level input | Vcc=3.0V to 3.6V (Note 3) | 0.8 | 1.1 | | V |
| RoH | Output impedance (HIGH state) | Note 2 | 28 | 34 | 43 | ohm |
| RoL | Output impedance (LOW state) | Note 2 | 28 | 35 | 43 | ohm |
| VOH | HIGH level output (Note 3) | Vcc=3.0V Io=6mA Vcc=3.0V Io=4mA Vcc=3.0V Io=100µA | 2.2 2.4 2.8 | 2.7 | | V |
| VOL | LOW level output (Note 3) | Vcc=3.0V Io=6mA Vcc=3.0V Io=4mA Vcc=3.0V Io=100µA | | 0.3 | 0.7 0.4 0.2 | V |
| IQ | Quiescent supply current | Vcc=3.6V VI=Vcc or GND Io=0 | | 330 | 600 | µA |
| I _{sup} | Supply current in suspend | Vcc=3.6V VI=Vcc or GND Io=0 | | | 70 | µA |
| IFS | Active supply current (Full Speed) | Vcc=3.3V | | 9 | 14 | mA |
| ILS | Active supply current (Low Speed) | Vcc=3.3V | | 2 | | mA |
| I _{Leak} | Input leakage current | Vcc=3.6V VI=5.5V or GND, not for I/O Pins | | +/-0.1 | +/-0.5 | µA |
| IOFF | 3-state output OFF-state current | Vi=Vih or Vil; Vo=Vcc or GND | | | +/-10 | µA |

NOTES:

1. All typical values are at Vcc=3.3V and Tamb=25 °C.
2. This value includes an external resistor of 24 ohm +/-1%. See "Load D+ and D-" diagram for testing details.
3. All signals except D+ and D-.



AC ELECTRICAL CHARACTERISTICS

Table 6.8 ACElectricalCharacteristics

GND=0V, $t_r = t_f = 3.0$ ns; $C_L = 50$ pF; $R_L = 500$ Ohms

| SYMBOL | PARAMETER | WAVEFORM | LIMITS (T_{AMB}) | | | | | UNIT |
|------------------------------|--|----------|----------------------|------------|----------------------|----------------|----------------------|------|
| | | | 0 °C to +25 °C | | | 0 °C to +70 °C | | |
| | | | MIN | TYP | MAX | MIN | MAX | |
| tpLH tpHL | VMO/VPO to D+/D- Full Speed | 1 | 0 0 | | 12 12 | 0 0 | 14 14 | ns |
| trise tfall | Rise and Fall Times Full Speed | 2 | 4 4 | 9 9 | 20 20 | 4 4 | 20 20 | ns |
| tRFM | Rise and Fall Time Matching Full Speed | | 90 | | 110 | 90 | 110 | % |
| tpLH tpHL | VMO/VPO to D+/D- Low Speed | 1 | | 120 120 | 300 300 | | 300 300 | ns |
| trise tfall | Rise and Fall Times Low Speed | 2 | 75 75 | | 300 200 | 75 75 | 300 200 | ns |
| tRFM | Rise and Fall Time Matching Low Speed | | 70 | | 130 | 70 | 130 | % |
| tpLH tpHL | D+/D- to RCV | 3 | | 9 9 | 16 16 | | 16 16 | ns |
| tpLH tpHL | D+/D- to VP/VM | 1 | | 4 4 | 8 8 | | 8 8 | ns |
| tpHZ tpZH tpLZ tpZL | OE# to D+/D- $R_L =$ 500ohm | 4 | | | 12 12 10 10 | | 12 12 10 10 | ns |
| tsu | Setup for SPEED | 5 | 0 | | | | | ns |
| Vcr | Crossover point ¹ | 3 | 1.3 | | 2.0 | 1.3 | 2.0 | V |

NOTES:

1. The crossover point is in the range of 1.3V to 2.5V for the low speed mode with a 50 pF capacitance.

Figure 6.2 Electrical Characteristics Diagram

AC WAVEFORM 1.

D+/D- TO VP/VM OR VPQ/VMO TO D+/D-

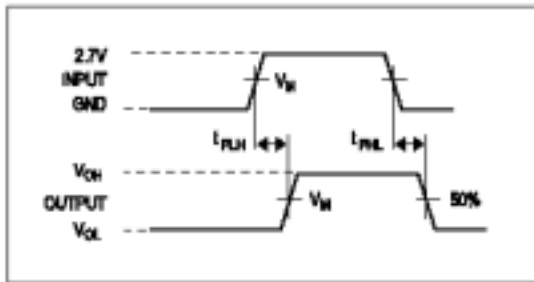

AC WAVEFORM 2.

RISE AND FALL TIMES

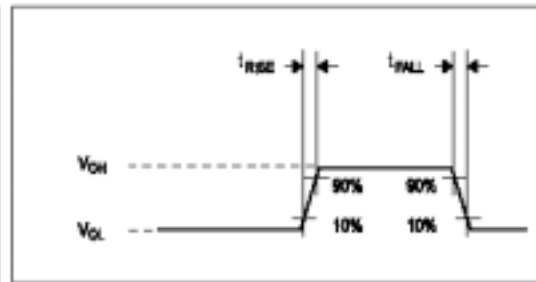

AC WAVEFORM 3.

D+/D- TO RCV

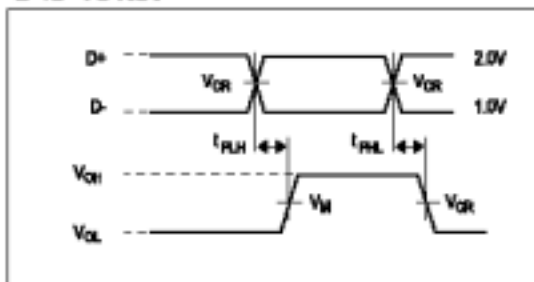

AC WAVEFORM 4.

OE# TO D+/D-

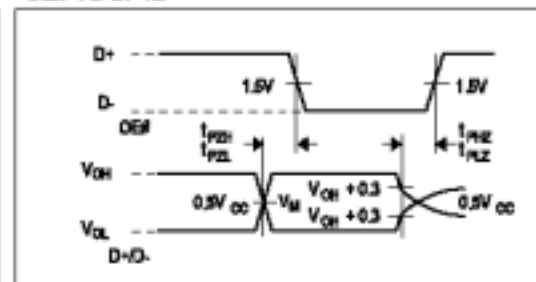

AC WAVEFORM 5.

SETUP FOR SPEED

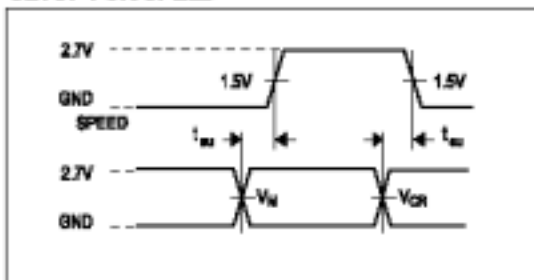

TEST CIRCUIT 1.

LOAD FOR VM/VP AND RCV

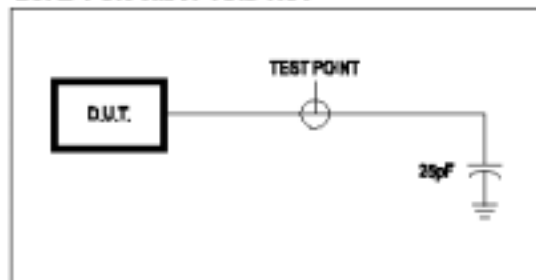

TEST CIRCUIT 2.

LOAD FOR ENABLE AND DISABLE TIMES

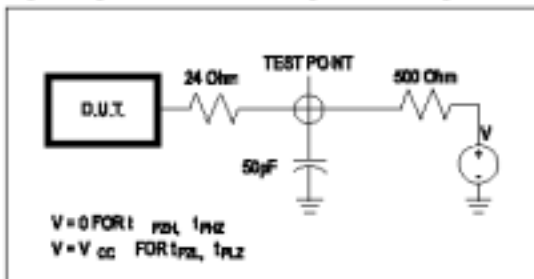

TEST CIRCUIT 3.

LOAD FOR D+/D-

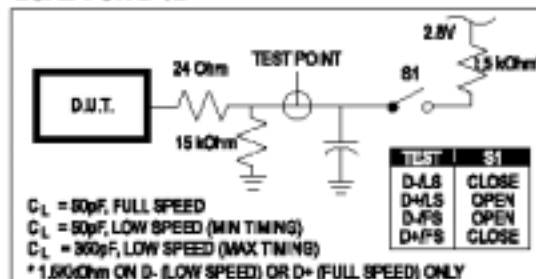



6.7 ESD Test Results

Test Description: ESD Testing was performed on a Zapmaster system using the Human-Body-Model (HBM) and Machine-Model (MM), according to MIL-STD 883 and EIAJ IC-121 respectively

- Human-Body-Model stresses devices by sudden application of a high voltage supplied by a 100pF capacitor through 1.5k-ohm resistance.
- Machine-Model stresses devices by sudden application of a high voltage supplied by a 200pF capacitor through very low (0 ohm) resistance.

Test circuit & condition

- Zap Interval: 1 second
- Number of Zaps: 3 positive and 3 negative at room temperature
- Criteria: I-V Curve Tracing

Table 6.9 ESD Data

| Model | Mode | S/S | Target | Results |
|-------|---------------|-----|--------|---------|
| HBM | Vdd, Vss, I/C | 15 | 6000V | PASS |
| MM | Vdd, Vss, I/C | 15 | 200V | PASS |

6.8 Latch-Up Test Results

Test Description: Latch-Up testing was performed at room ambient using an IMCS-4600 system which applies a stepped voltage to one pin per device with all other pins open except Vdd and Vss which were biased to 5Volts and ground respectively.

Testing was started at 5.0V (Positive) or 0V (Negative), and the DUT was biased for 0.5 seconds.

If neither the PUT current supply nor the device current supply reached the predefined limit (DUT=00mA, Icc=100mA), then the voltage was increased by 0.1Volts and the pin was tested again.

This procedure was recommended by the JEDEC JC-40.2 CMOS Logic standardization committee.

Notes:

1. DUT: Device Under Test.
2. PUT: Pin Under Test.

Figure 6.3 Latch-Up Test Results Diagram

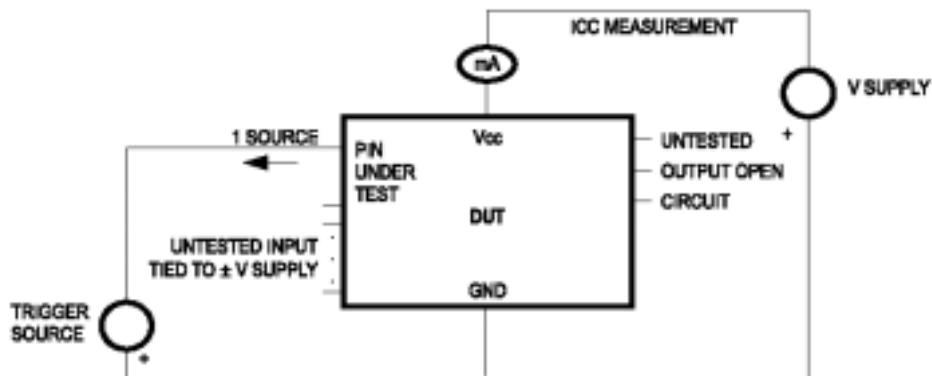

Test Circuit: Positive Input/Output Overvoltage/Overcurrent

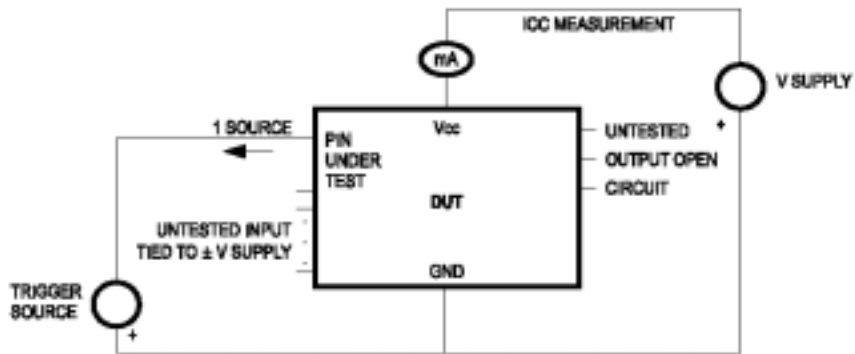

Test Circuit: Negative Input/Output Overvoltage/Overcurrent

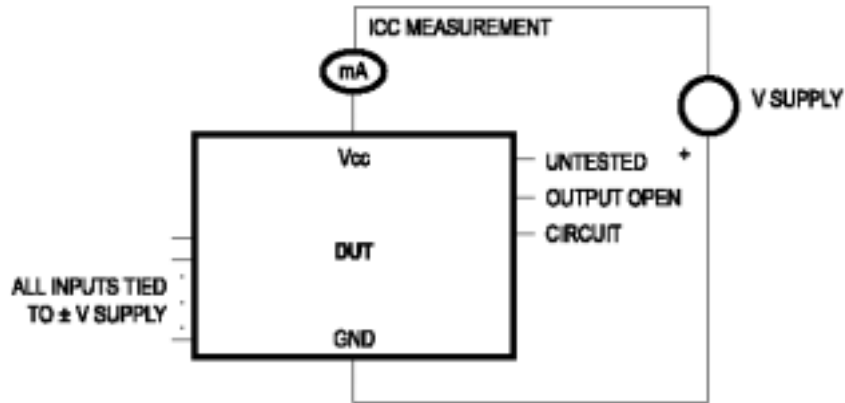

Supply Overvoltage Test

Table 6.10 Latch-Up Data Table

| Mode | | Voltage (V)/Current (mA) | S/S | Results |
|-----------|---|--------------------------|-----|---------|
| Voltage | + | 11.0 | 5 | Pass |
| | - | 11.0 | 5 | Pass |
| Current | + | 200 | 5 | Pass |
| | - | 200 | 5 | Pass |
| Vdd - Vxx | | 9.0 | 5 | Pass |



7.0 Mechanical Information

Figure 7.1 Mechanical Information Diagram

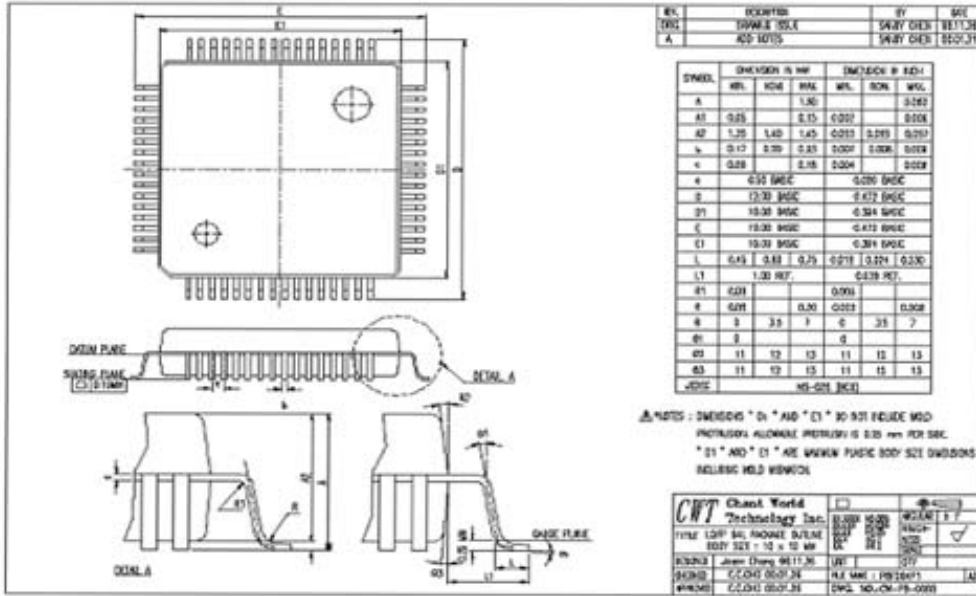

Table 7.1 Mechanical Information Table

| body size | | lead count | A1 | A2 | L1 | b | c | e |
|-----------|----|------------|-----|-----|----|-----|-------|-----|
| D1 | E1 | | | | | | | |
| 14 | 14 | 100 | 0.1 | 1.4 | 1 | 0.2 | 0.127 | 0.5 |

| | |
|----|----------------|
| A1 | stand-off |
| A2 | body thickness |
| L1 | lead length |
| b | lead width |
| c | lead thickness |
| e | lead pitch |



8.0 Abbreviations

This chapter lists and defines terms and abbreviations used throughout this specification.

| | |
|------------|-------------------------|
| SIE | Serial Interface Engine |
| CF | Compact Flash |
| MD | Micro Drive |
| SMC | SmartMedia Card |
| MS | Memory Stick |
| SD | Secure Digital |
| MMC | Multimedia Card |



【MEMO】

About Alcor Micro, Corp

Alcor Micro, Corp. designs, develops and markets highly integrated and advanced peripheral semiconductor, and software driver solutions for the personal computer and consumer electronics markets worldwide. We specialize in USB solutions and focus on emerging technology such as USB and IEEE 1394. The company offers a range of semiconductors including controllers for USB hub, integrated keyboard/USB hub and USB Flash memory card reader...etc. Alcor Micro, Corp. is based in Taipei, Taiwan, with sales offices in Taipei, Japan, Korea and California.

Alcor Micro is distinguished by its ability to provide innovative solutions for spec-driven products. Innovations like single chip solutions for traditional multiple chip products and on-board voltage regulators enable the company to provide cost-efficiency solutions for the computer peripheral device OEM customers worldwide.