



# Data Book

## AU9321 USB Compact Flash Card Reader Technical Reference Manual

**Product Specification**

**Official Release**

**Revision 1.00W**

**Public**

**Feb 2005**



## Data sheet status

Objective specification	This data sheet contains target or goal specifications for product development.
Preliminary specification	This data sheet contains preliminary data; supplementary data may be published later.
Product specification	This data sheet contains final product specifications.

## Revision History

Date	Revision	Description
Feb 2005	1.00W	Removed the schematics. Please contact our sales if you need it.



**Copyright Notice**

Copyright 1997 - 2005  
Alcor Micro Corp.  
All Rights Reserved.

**Trademark Acknowledgements**

The company and product names mentioned in this document may be the trademarks or registered trademarks of their manufacturers.

**Disclaimer**

Alcor Micro Corp. reserves the right to change this product without prior notice. Alcor Micro Corp. makes no warranty for the use of its products and bears no responsibility for any error that appear in this document. Specifications are subject to change without prior notice

**Contact Information:**

**Web site:** <http://www.alcormicro.com/>

**Taiwan**

Alcor Micro Corp.  
4F, No 200 Kang Chien Rd., Nei Hu,  
Taipei, Taiwan, R.O.C.  
Phone: 886-2-8751-1984  
Fax: 886-2-2659-7723

**Santa Clara Office**

2901 Tasman Drive, Suite 206  
Santa Clara, CA 95054  
USA  
Phone: (408) 845-9300  
Fax: (408) 845-9086

**Los Angeles Office**

9070 Rancho Park Court  
Rancho Cucamonga, CA.91730  
USA  
Phone: (909) 483-9900  
Fax: (909) 944-0464



# Table of Contents

<b>1</b>	<b><u><a href="#">Introduction</a></u></b> .....	<b>6</b>
	<u><a href="#">1.1 Description</a></u> .....	6
	<u><a href="#">1.2 Features</a></u> .....	6
<b>2</b>	<b><u><a href="#">Application Block Diagram</a></u></b> .....	<b>7</b>
<b>3</b>	<b><u><a href="#">Pin Assignment</a></u></b> .....	<b>8</b>
<b>4</b>	<b><u><a href="#">System Architecture and Reference Design</a></u></b> .....	<b>10</b>
	<u><a href="#">4.1 AU9321 Block Diagram</a></u> .....	10
<b>5</b>	<b><u><a href="#">Electrical Characteristics</a></u></b> .....	<b>11</b>
	<u><a href="#">5.1 Recommended Operating Conditions</a></u> .....	11
	<u><a href="#">5.2 General DC Characteristics</a></u> .....	11
	<u><a href="#">5.3 DC Electrical Characteristics for 3.3 volts operation</a></u> .....	11
	<u><a href="#">5.4 Crystal Oscillator Circuit Setup for Characteristics</a></u> .....	12
	<u><a href="#">5.5 ESD Test Results</a></u> .....	12
	<u><a href="#">5.6 Latch-Up Test Results</a></u> .....	13
<b>6</b>	<b><u><a href="#">Mechanical Information</a></u></b> .....	<b>15</b>



## List of Figures

2.1	<a href="#">Block Diagram</a> .....	7
3.1	<a href="#">Pin Assignment Diagram</a> .....	8
4.1	<a href="#">AU9321 Block Diagram</a> .....	10
5.1	<a href="#">Crystal Oscillator Circuit Setup for Characterization</a> .....	12
5.2	<a href="#">Latch-Up Test Results</a> .....	13
6.1	<a href="#">Mechanical Information Diagram</a> .....	15

## List of Tables

3.1	<a href="#">Pin Descriptions</a> .....	9
5.1	<a href="#">Recommended Operating Conditions</a> .....	11
5.2	<a href="#">General DC Characteristics</a> .....	11
5.3	<a href="#">DC Electrical Characteristics for 3.3 volts operation</a> .....	11
5.4	<a href="#">ESD Test Results</a> .....	12
5.5	<a href="#">Latch-Up Data</a> .....	14



# 1.0 Introduction

## 1.1 Description

The AU9321 is a single chip integrated USB Compact Flash (CF) card reader controller. It can be used as a removable storage disk in enormous data exchange applications between PC and PC or PC and various consumer electronic devices.

The AU9321 can read of CF card's contents created by handheld consumer electronic devices such as digital camera, MP3 player, PDA and mobile phone... etc. It provides a faster and convenient way of data transfer scheme to meet the emerging need of a data exchange center between PC and various consumer devices. With AU9320, users' experience will be further enhanced by the Plug-and-Play nature built into latest operation systems such as Windows 2000/XP and Mac OS X.

Because of the multiple sectors transfer up to 4G bytes and the single chip integration, AU9321 will be the most powerful and cost efficient CF card reader controller solution in the market.

## 1.2 Features

- Support USB v1.1 specification and USB Device Class Definition for Mass Storage, Bulk-Transport v1.0.
- Support Compact Flash (CF) v1.4 Specification.
- Work with default driver from Windows ME, Windows 2000, Windows XP, Mac OS 9.1, and Mac OS X. Windows 98 is supported by vendor driver from Alcor.
- Ping-pong FIFO implementation for concurrent bus operation.
- Support multiple sectors transfer up to 4G byte to optimize performance.
- Support optional external EEPROM for USB VID, PID and string customization.
- Capable of handing 8 sets of built-in PID, VID and strings to minimize inventory control and improve lead production lead time.
- LED for bus activity monitoring.
- Integrated power switch and power management circuit to meet USB 500uA power consumption during suspend with CF card in the slot.
- Runs at 12MHz, built-in 48 MHz PLL.
- Built-in 3.3V regulator.
- 48-pin LQFP package

## 2.0 Application Block Diagram

Following is the application diagram of a typical flash memory card reader using AU9321. By connecting the reader to a PC through USB bus, the AU9321 is acting as a bridge between the flash memory card from digital camera, MP3 player, PDA or mobile phone and PC.

Figure 2.1 Block Diagram

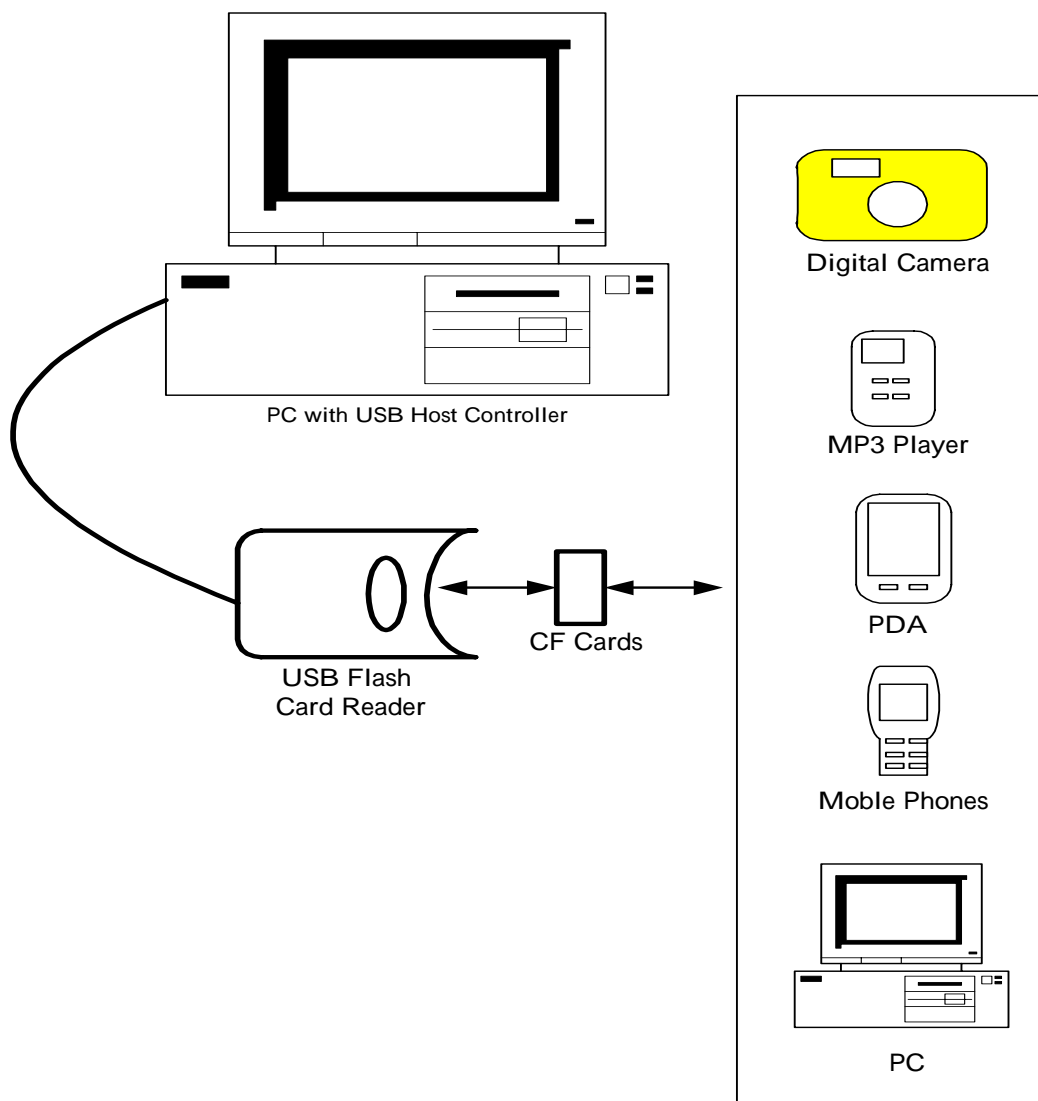

# 3.0 Pin Assignment

The AU9321 is packed in 48-LQFP form factor. The following figure shows signal name for each pin and the table in the following page describes each pin in detail.

**Figure 3.1 Pin Assignment Diagram**

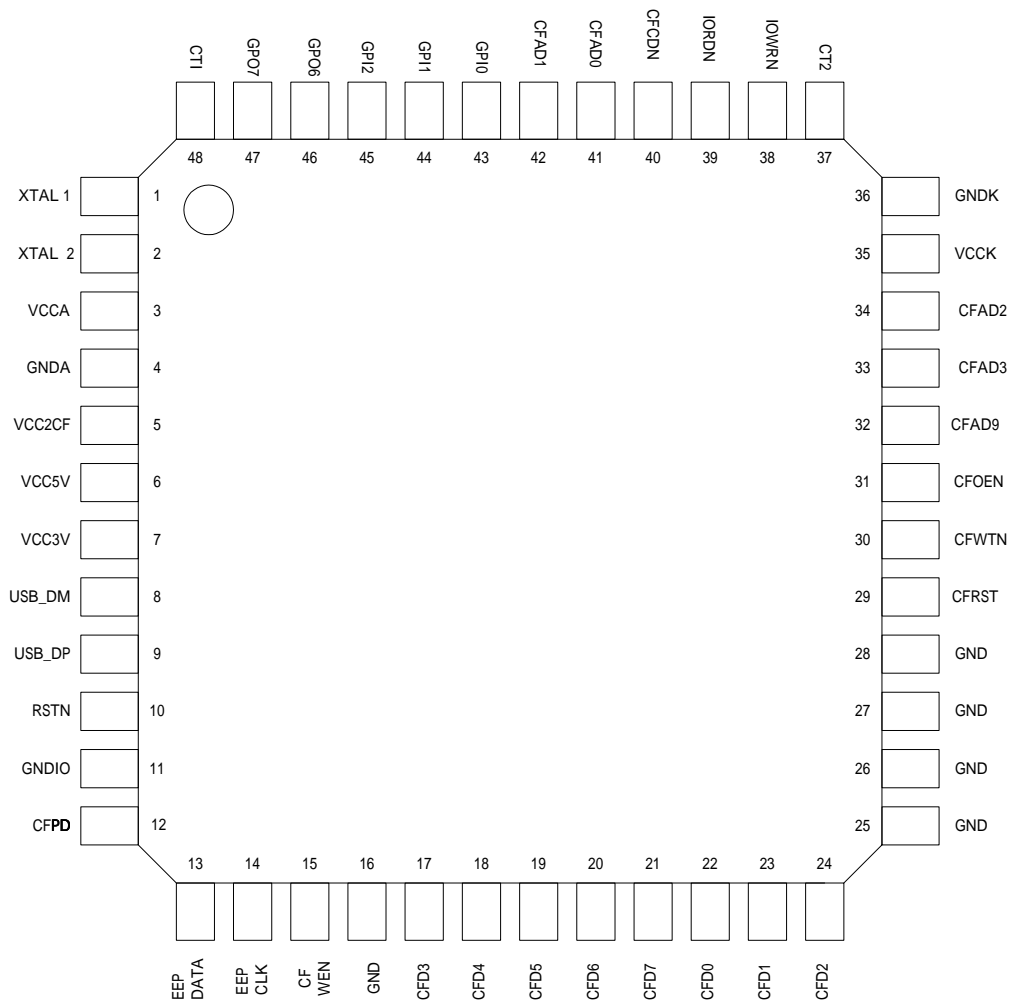

**Table 3.1 Pin Descriptions**

Pin	Name	IO Type	Description
1	XTAL1	Input	Crystal Oscillator Input (12MHz)
2	XTAL2	Output	Crystal Oscillator Output (12MHz)
3	VCCA	Power	Analog Vcc, Connected to 3.3V
4	GND4	Ground	Connected to Ground
5	VCC2CF	Power	CF Power
6	VCC5V	Power	5V Power Supply
7	VCC3V	Output	Regulated 3.3V out
8	USB_DM	Input/Output	USB D-
9	USB_DP	Input/Output	USB D+
10	RSTN	Input	Hardware reset (Active Low)
11	GNDIO	Ground	Ground
12	CFPD	Power	Power Down
13	EEPDATA	Input/Output	EEPROM Data
14	EEPCLK	Output	EEPROM Clock
15	CFWEN	Output	ArrIBUTE write enable
16	GND	Ground	Ground
17	CFD3	Input/Output	Compact Flash Data 3
18	CFD4	Input/Output	Compact Flash Data 4
19	CFD5	Input/Output	Compact Flash Data 5
20	CFD6	Input/Output	Compact Flash Data 6
21	CFD7	Input/Output	Compact Flash Data 7
22	CFD0	Input/Output	Compact Flash data 0
23	CFD1	Input/Output	Compact Flash data 1
24	CFD2	Input/Output	Compact Flash data 2
25	GND	Ground	Ground
26	GND	Ground	Ground
27	GND	Ground	Ground
28	GND	Ground	Ground
29	CFRST	Output	Compact Flash reset signal
30	CFWTN	Input	Compact Flash wait signal
31	CFOEN	Output	Compact Flash output enable
32	CFAD9	Output	Compact Flash address 9
33	CFAD3	Output	Compact Flash address 3
34	CFAD2	Output	Compact Flash address 2
35	VCKK	Power	Kernel Vcc
36	GNDK	Ground	Kernel Ground
37	CT2		Connected to Ground
38	IOWRN	Output	Compact Flash I/O write signal
39	IORDN	Output	Compact Flash I/O read signal
40	CFCDN	Input	Compact Flash Card Detect
41	CFAD0	Output	Compact Flash address 0
42	CFAD1	Output	Compact Flash address 1
43	GPIO	Input	General Purpose I (*1)
44	GPI1	Input	General Purpose I (*1)
45	GPI2	Input	General Purpose I
46	GPO6	Output	General Purpose Output
47	GPO7	Output	General Purpose Output, used for LED activity
48	CT1		Connected to Ground

# 4.0 System Architecture and Reference Design

## 4.1 AU9321 Block Diagram

Figure 4.1 AU9321 Block Diagram

Alcor Micro - AU9321 Flash Memory Card Reader Block Diagram

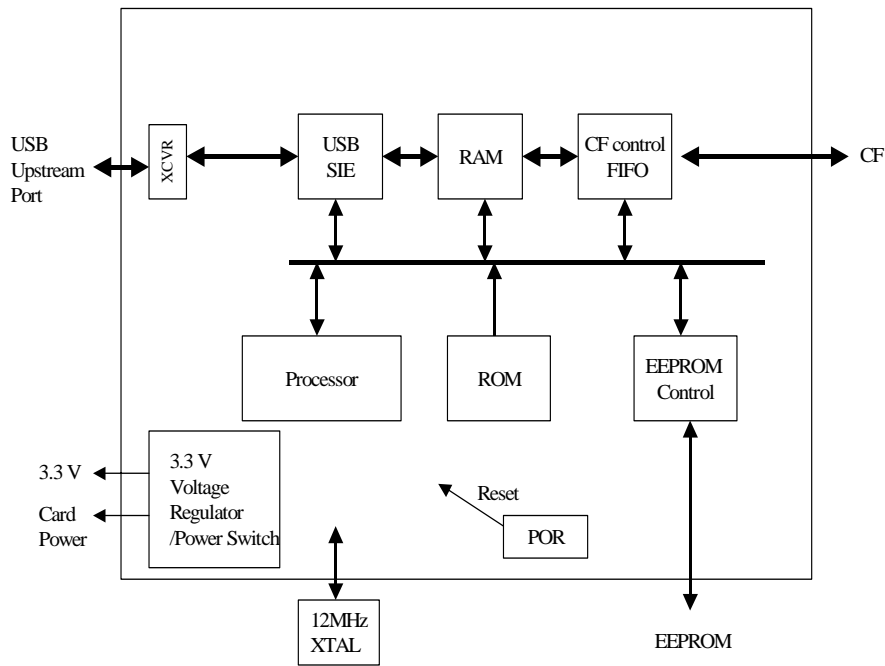



## 5.0 Electrical Characteristics

### 5.1 Recommended Operating Conditions

Table 5.1 Recommended Operating Conditions

SYMBOL	PARAMETER	MIN	TYP	MAX	UNITS
V <sub>CC</sub>	Power Supply	4.75	5	5.25	V
V <sub>IN</sub>	Input Voltage	0		V <sub>CC</sub>	V
T <sub>OPR</sub>	Operating Temperature	0		85	°C
T <sub>STG</sub>	Storage Temperature	-40		125	°C

### 5.2 General DC Characteristics

Table 5.2 General DC Characteristics

SYMBOL	PARAMETER	CONDITIONS	MIN	TYP	MAX	UNITS
I <sub>IL</sub>	Input low current	no pull-up or pull-down	-1		1	μA
I <sub>IH</sub>	Input high current	no pull-up or pull-down	-1		1	μA
I <sub>OZ</sub>	Tri-state leakage current		-10		10	μA
C <sub>IN</sub>	Input capacitance			5		ρF
C <sub>OUT</sub>	Output capacitance			5		ρF
C <sub>BID</sub>	Bi-directional buffer capacitance			5		ρF

### 5.3 DC Electrical Characteristics for 3.3 volts operation

Table 5.3 DC Electrical Characteristics for 3.3 volts operation

SYMBOL	PARAMETER	CONDITIONS	MIN	TYP	MAX	UNITS
V <sub>IL</sub>	Input Low Voltage	CMOS			0.9	V
V <sub>IH</sub>	Input High Voltage	CMOS	2.3			V
V <sub>OL</sub>	Output low voltage	I <sub>OL</sub> =4mA, 16mA			0.4	V
V <sub>OH</sub>	Output high voltage	I <sub>OH</sub> =4mA, 16mA	2.4			V
R <sub>I</sub>	Input Pull-up/down resistance	V <sub>IL</sub> =0V or V <sub>IH</sub> =V <sub>CC</sub>		10k/200k		KΩ

## 5.4 Crystal Oscillator Circuit Setup for Characterization

The following setup was used to measure the open loop voltage gain for crystal oscillator circuits. The feedback resistor serves to bias the circuit at its quiescent operating point and the AC coupling capacitor,  $C_s$ , is much larger than  $C_1$  and  $C_2$ .

Figure 5.1 Crystal Oscillator Circuit Setup for Characterization

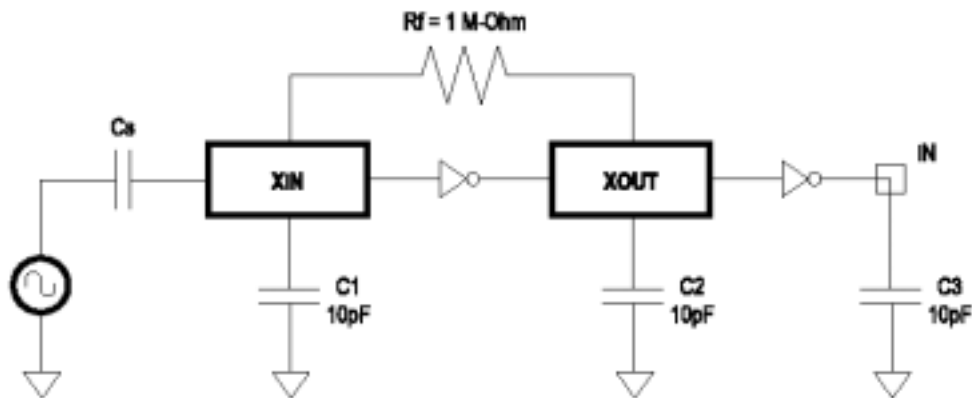

## 5.5 ESD Test Results

**Test Description :** ESD Testing was performed on a Zapmaster system using the Human-Body –Model (HBM) and Machine-Model (MM), according to MIL\_STD 883 and EIAJ IC\_121 respectively.

- Human-Body-Model stress devices by sudden application of a high voltage supplied by a 100 PF capacitor through 1.5 Kohm resistance.
- Machine-Model stresses devices by sudden application of a high voltage supplied by a 200 PF capacitor through very low (0 ohm) resistance

### Test circuit & condition

- Zap Interval : 1 second
- Number of Zaps : 3 positive and 3 negative at room temperature
- Criteria : I-V Curve Tracing

Table 5.4 ESD Test Results

Model	Model	S/S	TARGET	Results
HBM	Vdd, Vss, I/C	15	4000V	Pass
MM	Vdd, Vss, I/C	15	200V	Pass

## 5.6 Latch-Up Test Results

**Test Description:** Latch-Up testing was performed at room ambient using an IMCS-4600 system which applies a stepped voltage to one pin per device with all other pins open except Vdd and Vss which were biased to 5 Volts and ground respectively.

Testing was started at 5.0 V (Positive) or 0 V(Negative), and the DUT was biased for 0.5 seconds.

If neither the PUT current supply nor the device current supply reached the predefined limit (DUT=0 mA , Icc=100 mA), then the voltage was increased by 0.1 Volts and the pin was tested again.

This procedure was recommended by the JEDEC JC-40.2 CMOS Logic standardization committee.

**Notes:**

1. DUT: Device Under Test.
2. PUT: Pin Under Test.

**Figure 5.2 Latch-Up Test Results**

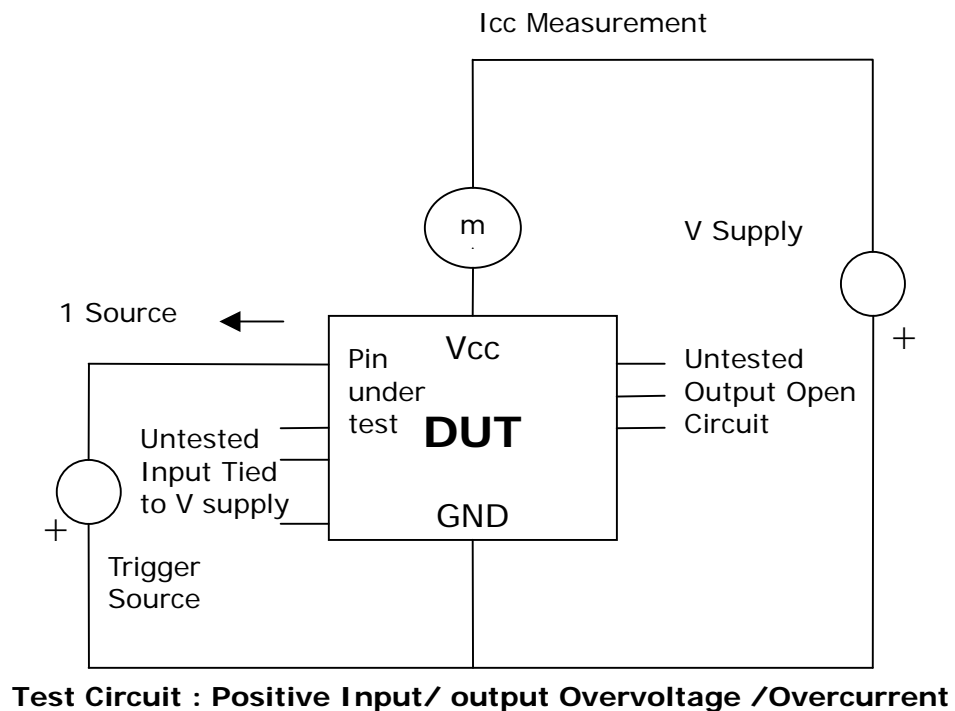

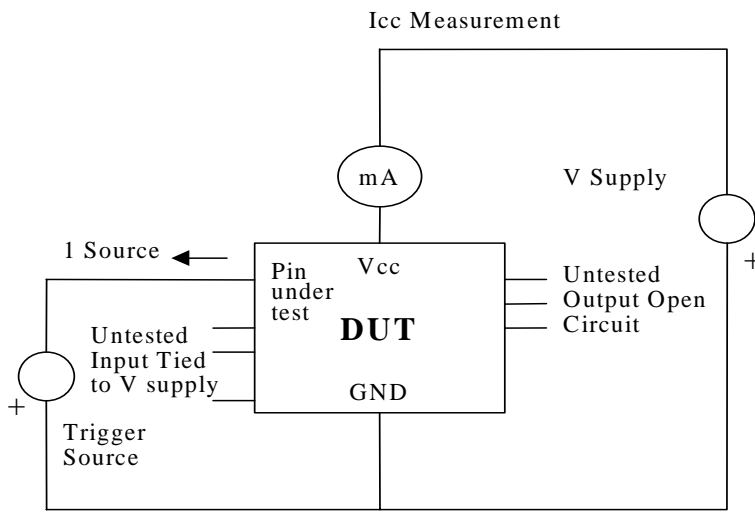

**Test Circuit : Negative Input/Output Overvoltage/Overcurrent**

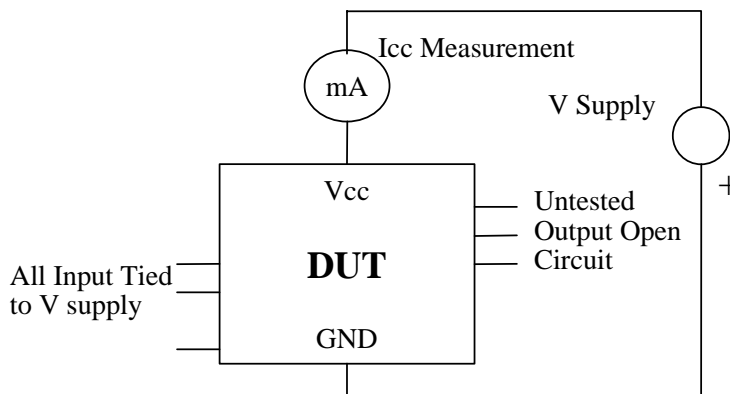

**Supply Voltage Test**

**Table 5.5 Latch-Up Data**

Model	Model	Voltage (v)/ Current (mA)	S/S	Results
Voltage	+	11.0	5	Pass
	-	11.0		
Current	+	200	5	
	-	200		
Vdd-Vxx		9.0	5	Pass

## 6.0 Mechanical Information

Figure 6.1 Mechanical Information Diagram

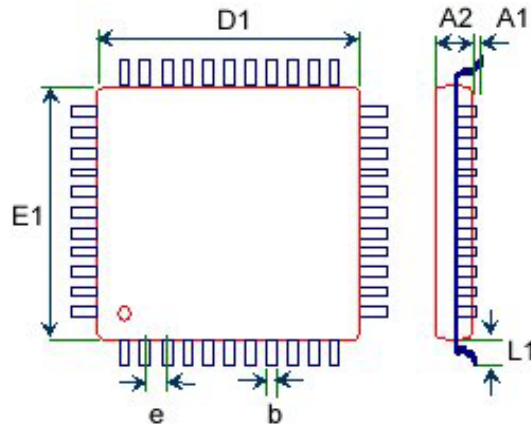

body size		lead count	A1	A2	L1	b	c	e
D1	E1							
7	7	48	0.1	1.4	1	0.2	0.127	0.5

A1	stand-off
A2	body thickness
L1	lead length
b	lead width
c	lead thickness
e	lead pitch



**【MEMO】**

### **About Alcor Micro, Corp**

Alcor Micro, Corp. designs, develops and markets highly integrated and advanced peripheral semiconductor, and software driver solutions for the personal computer and consumer electronics markets worldwide. We specialize in USB solutions and focus on emerging technology such as USB and IEEE 1394. The company offers a range of semiconductors including controllers for USB hub, integrated keyboard/USB hub and USB Flash memory card reader...etc. Alcor Micro, Corp. is based in Taipei, Taiwan, with sales offices in Taipei, Japan, Korea and California.

Alcor Micro is distinguished by its ability to provide innovative solutions for spec-driven products. Innovations like single chip solutions for traditional multiple chip products and on-board voltage regulators enable the company to provide cost-efficiency solutions for the computer peripheral device OEM customers worldwide.